



CE

319U16EN

CONTROL PANEL
FOR 24V OPERATORS

Z 24 SERIES



INSTALLATION MANUAL

ZL90



English

EN

“IMPORTANT INSTALLATION, SAFETY INSTRUCTIONS”

“CAUTION: IMPROPER INSTALLATION MAY CAUSE SERIOUS DAMAGE, FOLLOW ALL INSTALLATION INSTRUCTIONS CAREFULLY”

“THIS MANUAL IS ONLY FOR PROFESSIONAL INSTALLERS OR QUALIFIED PERSONS”



1 Legend of symbols



This symbol indicates sections to be read with particular care.



This symbol indicates sections concerning safety



This symbol indicates notes to communicate to users.

2 Intended use and application

2.1 - INTENDED USE

The ZL90 control panel is designed to control the FROGJ and A1824 swing gate operators

 The use of this product for purposes other than as described above and installation executed in a manner other than as instructed in this technical manual are prohibited.

2.2 - APPLICATION

Make sure you respect the distances and cable diameters as shown in “cable types and minimal thicknesses” table.

The overall power of the motors must not exceed 480W.

3 Reference Standards

For its quality processes management Came Cancelli Automatici is ISO 9001:2000 certified, and for its environmental management it is ISO 14001 certified. Came designs and manufactures entirely in Italy.

This product complies with the following standards: see Conformity declaration.

4 Description

This product is engineered and manufactured by CAME cancelli automatici s.p.a. and complies with current safety regulations.

The control panel works on 230V a.c. of power, through the terminals L-N, 50/60Hz frequency.

Both command and control devices and accessories are 24V powered. Warning! Accessories must not exceed 37 W overall.

The control unit is fitted with an amperometric device which constantly regulates the motor's drive coefficient.

When the gate runs into an obstacle, the amperometric sensor immediately detects an overcharge in the drive and redirects the gate's direction of movement, and:

- opens it if it is closing⁽¹⁾;
- closes it if it is opening.

⁽¹⁾ Warning!: in this case, after 3 consecutive obstacle detections, the gate will stop open excluding the automatic closing function; for movement to start again press the command button or use the remote control.

All connections are protected by quick fuses, see table.

The card provides and controls the following functions:

- automatic closing after an open-command;
- pre-flashing by the motion indicator;
- obstacle detection when gate is still in any position;
- continual monitoring of photocell operation.

The following command modes are possible:

- open/close;
- open/close and maintained action;
- partially open;
- complete stop.

After detecting an obstacle and depending on the type of connection used, the photocells may cause:

- reopening of the gate when it is closing;
- partial stop or obstacle stand-by.

Apposite trimmers regulate:

- the automatic closing run time;
- the second gate leaf's motion time difference;
- the amperometric device's detection sensitivity, in separately in terms of normal opening and closing and braking;
- the operation and deceleration speed separately.

Further implemented options:

- connecting up an electric lock (alternatively to the “Open Gate” indicator light) and possibly adding the “Ram Blow” function.

TECHNICAL FEATURES

Power supply	230V - 50/60Hz
max. rated power	480 W
Power draw when idling	90 mA
Max power of 24V accessories	37 W
Insulation rating	II
Material	ABS
Protection rating	IP54
operating temperature	-20 / +55°C

FUSES

protection	fuse type
Motor/s	6.3 A-F
Electronic board (power supply line)	1.6 A-F
Accessories	1.6 A-F
Control devices	1 A-F

4.1 - DIMENSIONS, SPANS AND ANCHORING HOLES

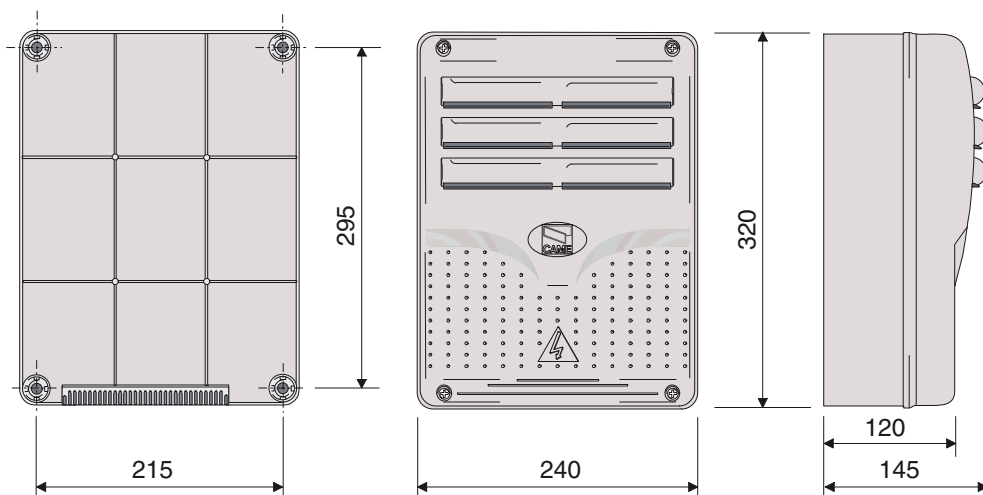

4.2 - MAIN COMPONENTS

1. Transformer
2. M1 motor fuse
3. M2 motor fuse
4. Line fuse
5. Accessories fuse
6. Control unit fuse
7. Buttons for calibrating the stroke
8. Buttons for memorising the radio code
9. Control and signalling LED unit
10. Functions selectors (2 way)
11. Functions selector (10 way)
12. Plug for the remote control frequency card
13. terminal board for connecting the antenna
14. Terminal board for connecting accessories and control devices
15. Terminal board for connecting the gearmotors
16. Terminal board for 230V a.c. power grid

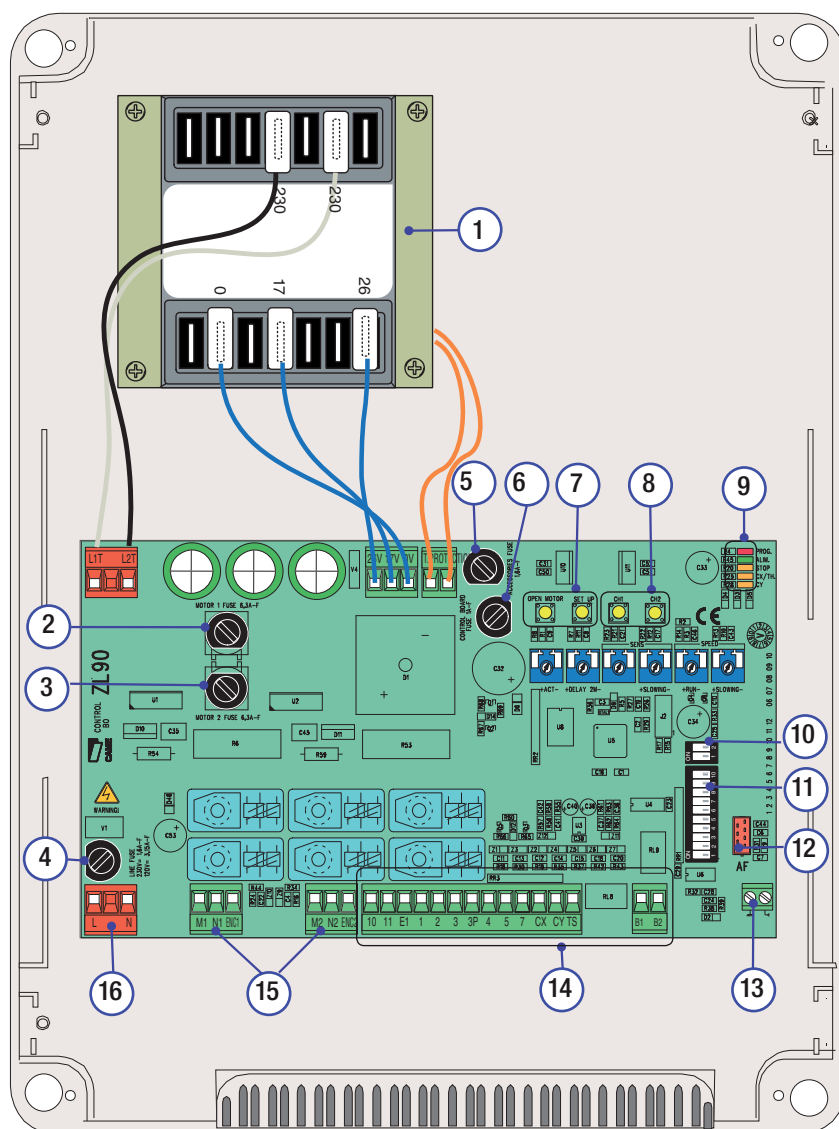

Warning! Before acting on the machinery, cut off the main power supply and disconnect any emergency batteries.

5 Installation

5.1 - PRELIMINARY CHECKS

 Before installing do the following:

- Check that the panel's anchoring point is protected from possible blows, and that the anchoring surface is solid. Also check that the anchoring is done using the appropriate bolts, screws etc.
- Make sure you have a suitable omnipolar cut-off device with contacts more than 3 mm apart, and independent (sectioned off) power supply.
-  Make sure that any connections inside the case (that provide continuance to the protective circuit) are fitted with extra insulation as compared to the other conductive parts inside;
- Make sure you have suitable tubing and conduits for the electrical cables to pass through and be protected against mechanical damage.

5.2 - TOOLS AND MATERIALS

Make sure you have all the tools and materials you will need for the installation at hand to work in total safety and compliance with the current standards and regulations. The following figure illustrates the minimum equipment needed by the installer. Here are some examples.

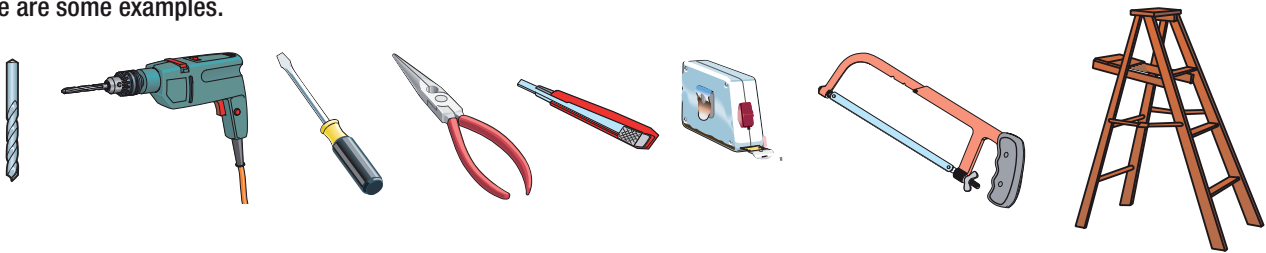

5.3 - FIXING AND MOUNTING THE BOX

Fix the base of the panel in a protected area; we suggest using round top Phillips recessed head screws of max. 6mm in diameter.

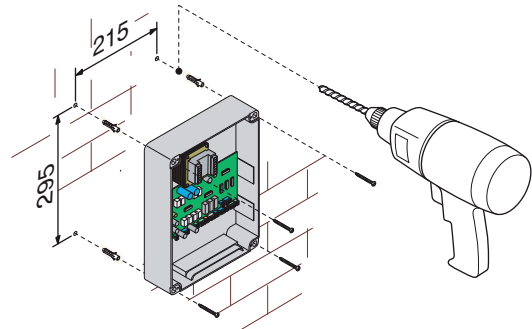

Perforate the pre-punched holes and insert the cable glands with the corrugated tubing for the electrical cables to travel through

N.B.: the pre-punched holes have the following diameters: 23mm 29 and 37 mm.

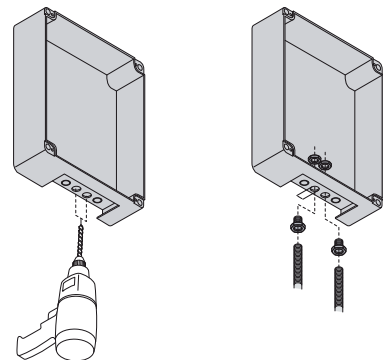

Assemble the pressure hinges.

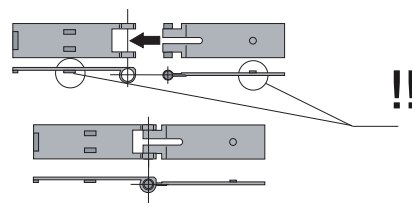

Insert the pressure hinges into the box (on the left or right as you wish) and set them using the provided screws and washers

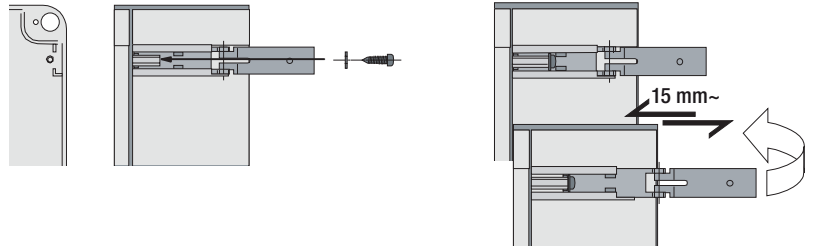

Snap the cover into place onto the hinges. Close it and fix it using the provided screws

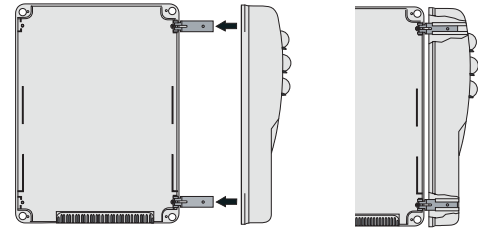

After the adjustments and settings, fix the cover using the provided screws.

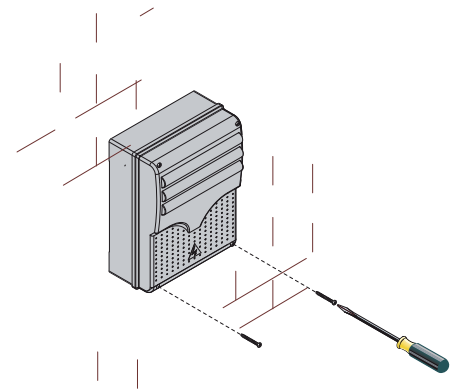

6 Electrical connections

6.1 - CABLE LIST AND MINIMUM THICKNESS

Connections	Type of cable	Length of cable 1 < 10 m	Length of cable 10 < 20 m	Length of cable 20 < 30 m
Control panel power supply 230V	FROR CEI 20-22 CEI EN 50267-2-1	3G x 1.5 mm ²	3G x 2.5 mm ²	3G x 4.0 mm ²
Motor power supply 24V		3 x 1.0 mm ²	3 x 1.5 mm ²	3 x 2.5 mm ²
flashing lamp		2 x 0.5 mm ²	2 x 1.0 mm ²	2 x 1.5 mm ²
Transmitter photocells		2 x 0.5 mm ²	2 x 0.5 mm ²	2 x 0.5 mm ²
Receiver photocells		4 x 0.5 mm ²	4 x 0.5 mm ²	4 x 0.5 mm ²
Power supply to accessories		2 x 0.5 mm ²	2 x 0.5 mm ²	2 x 1.0 mm ²
Control and safety devices		2 x 0.5 mm ²	2 x 0.5 mm ²	2 x 0.5 mm ²
Antenna connection	RG58	max. 10 m		

N.B.: If the cable length differs from that specified in the table, then you must determine the proper cable diameter based on the actual power draw from the connected devices and according to the CEI EN 60204-1 standards.

For connections that require several, sequential loads, the sizes given on the table must be re-evaluated based on actual power draw and distances.

When connecting products that are not specified in this manual, please follow the documentation provided with said products.

6.2 - CONNECTING TO THE GEARMOTORS

FROG-J / A1824

M1 - 24V d.c. gearmotor
featuring delayed action on opening

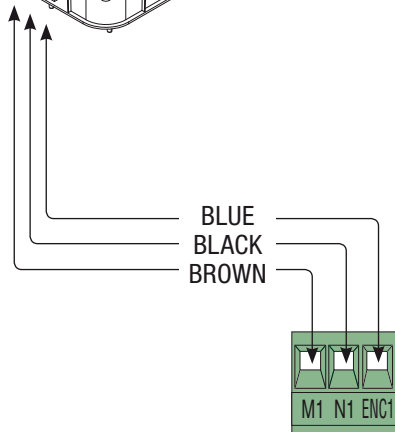
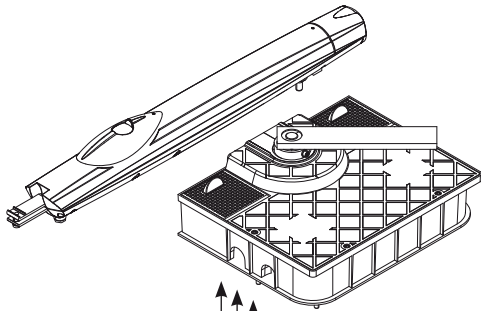

FROG-J / A1824

M2 - 24V d.c. gearmotor
featuring delayed action on closing

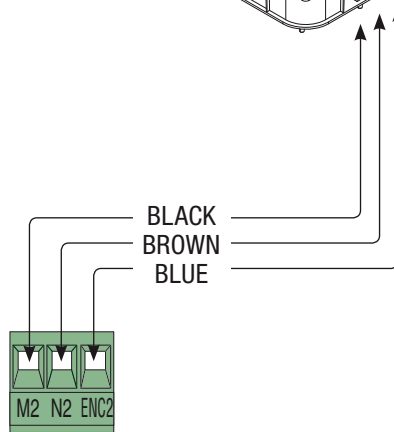
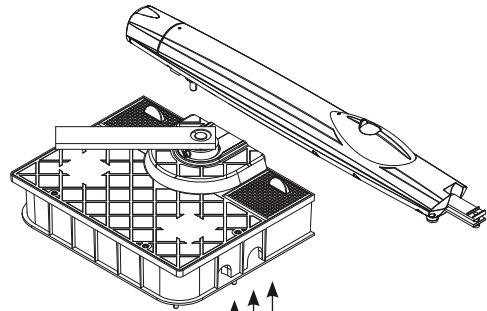

6.3 - POWER SUPPLY TO ACCESSORIES

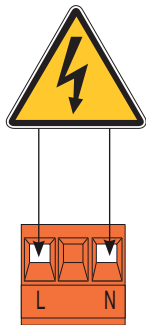

Power supply
230V (a.c.) 50/60 Hz



Terminals for powering the following accessories:

- 24V a.c. (normally alternated power)
- 24V a.c. (continuous power) when the emergency batteries are in operation.

Overall power allowed: 37W

6.4 - ELECTRICAL LOCK

ZL90 allows you to connect, **alternatively to the indicator light on 10-5**, a 12V (15W max) electrolock, and if necessary also the “Ram Blow” function.

After hooking it up as shown in the illustration, proceed as follows:

- Set **dip switch 6 to ON** (and dip switch 3 to OFF);
- press CH1**: the red PROG led will start to blink;
- when the **led stays on** (after about 5 seconds) the procedure is complete;
- set to the **dip switches back to OFF** (or to the previous position, which depends on the functions selection, see paragraph 7, page 10).

N.B.: to return to default (indicator lamp on 10-5), follow the same procedure while pressing CH2.

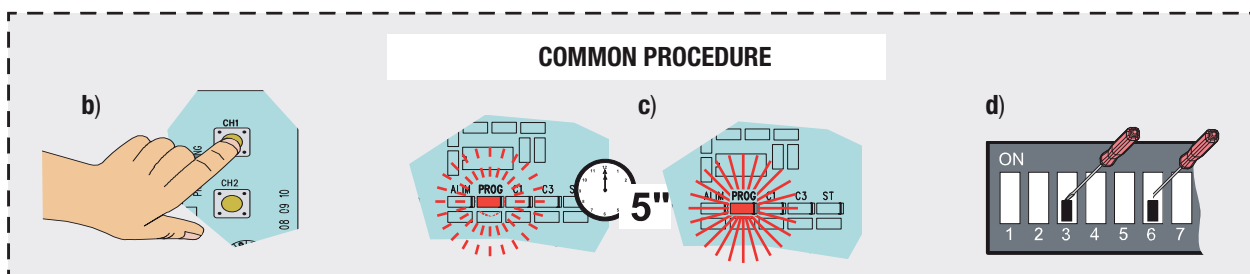
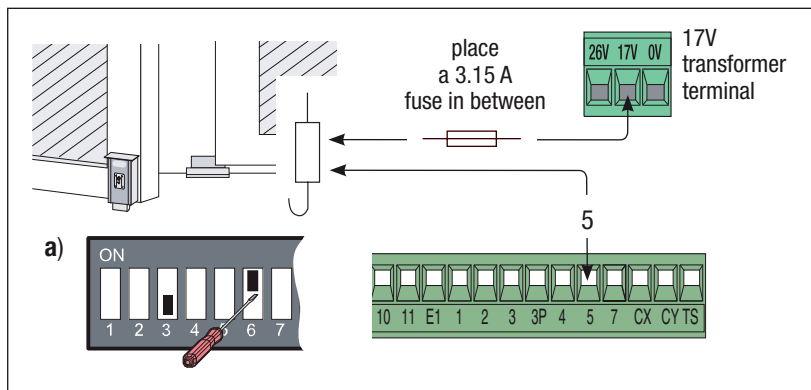

To activate the “ram blow” ⁽¹⁾:

- Set **dip switches 3 and 6 to ON**;
- b), c), d)** - continue with the above **COMMON PROCEDURE**.

N.B.: to exclude the ram blow, follow the same procedure while pressing CH2.

⁽¹⁾ Upon each opening command, the gate leaves press on the closing jamb for one second, assisting the electrolock release operation.

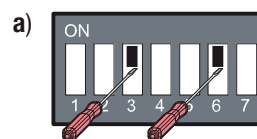

6.5 - SIGNALLING AND LIGHTING DEVICES

Signal Flasher
(socket rating: 24V - 25W max.)
Flashes during opening and closing phases

Open gate indicator-light
(socket rating: 24V - 3W max.).
Turns on when the gate is ajar or open.
It turns off when the gate is closed.
(Also see Chapt. 6.4)

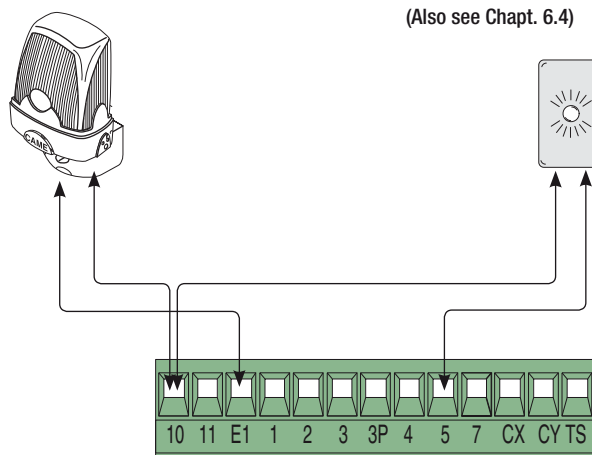

“partial stop” (N.C.) socket

- input for safety devices such as photocells, sensitive edges and other EN 12978-compliant devices. Halts moving gate leaves and causes them to automatically close

Dip 1 OFF - DIP 2 OFF (2 way dip)

- or -

“Stand-by Obstacle” (N.C.) socket

- Input for safety devices such as photocells, sensitive edges and other EN 12978 compliant devices. Halts the moving gate leaves causing them to start moving again once obstacle is removed.

Dip 1 OFF - DIP 2 ON (2 way dip)

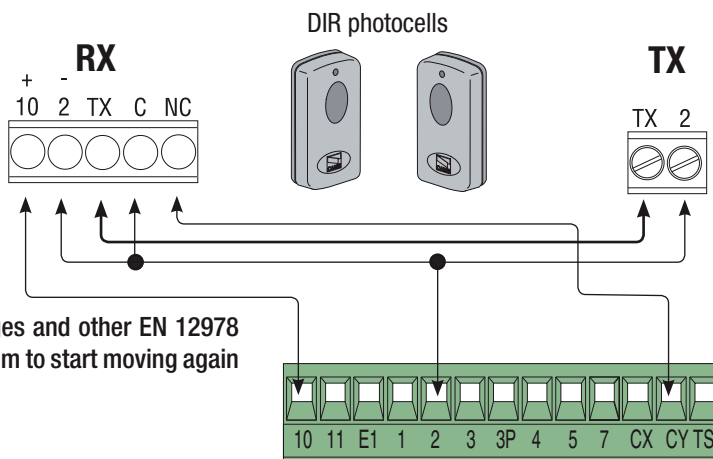

“Open during closing” (N.C.) socket

- Input for safety devices such as photocells, sensitive edges and other EN 12978 compliant devices. When gate leaves are closing, opening the contact causes reversal until total opening is obtained.

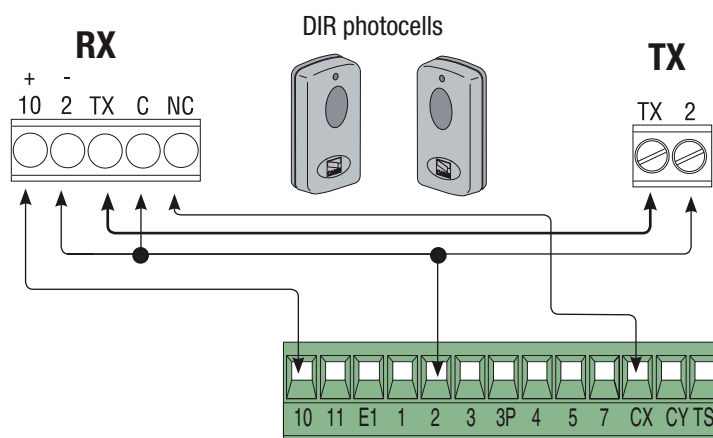

“Partial Stop” (N.C.) socket

Dip 1 OFF - DIP 2 OFF (2 way dip)

- or -

“Stand-by Obstacle” (N.C.) socket

Dip 1 OFF - DIP 2 ON (2 way dip)

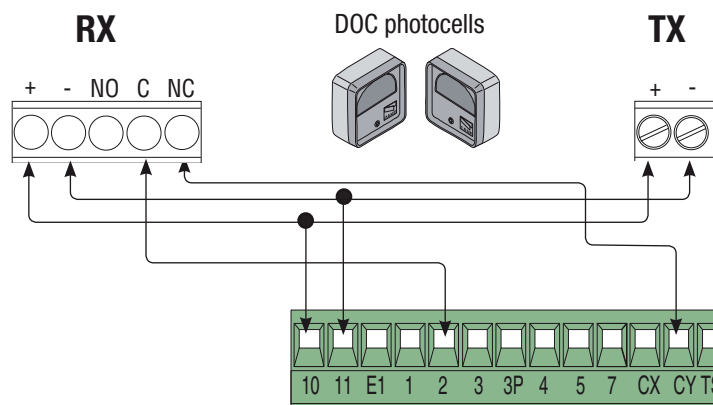

“Open during closing” (N.C.) socket

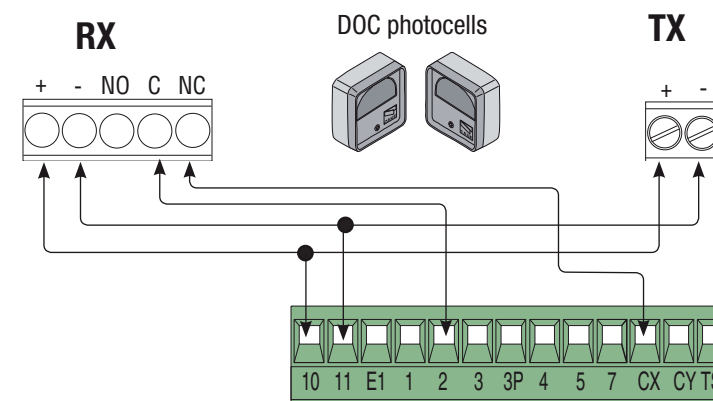

6.7 - COMMAND DEVICES

Stop button (N.C. socket)

- Button to stop gate while excluding the automatic closing cycle. For movement to resume you must press the command button or transmitter button.

Key selector and/or opening button (N.O. socket)

- Gate opening command.

Key selector and/or partial opening button (N.O. socket)

- Opening of one gate leaf to allow pedestrian passage.

Key selector and/or closing button (N.O. contact)

- gate closing command.

Key selector and/or commands button ()

- Gate closing and opening contacts, by pressing the button or turning the selector key, the gate movement is inverted or halted depending on which selection was just made. (see selecting functions, dips 2 and 3).

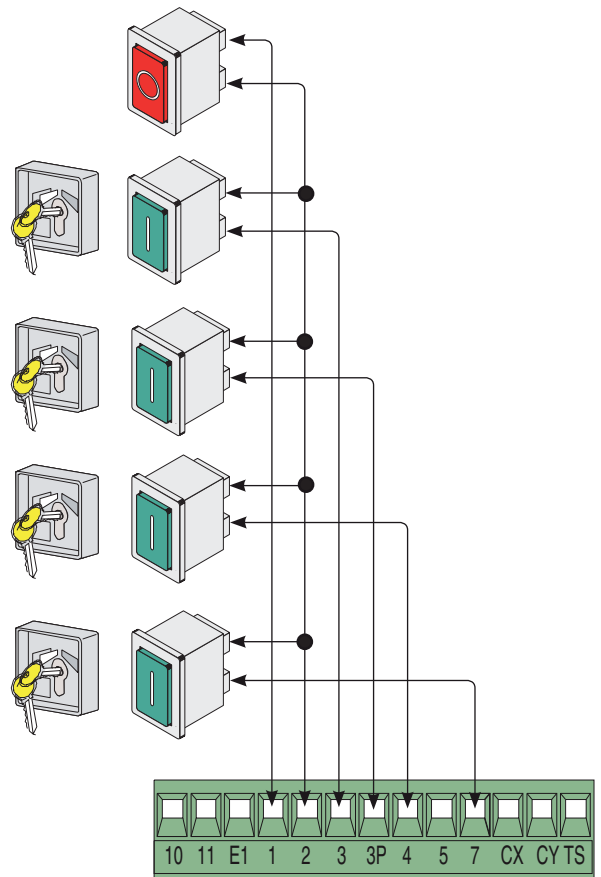

6.8 - ELECTRICAL CONNECTION FOR THE PHOTOCELLS FUNCTIONS TEST

(DOC)

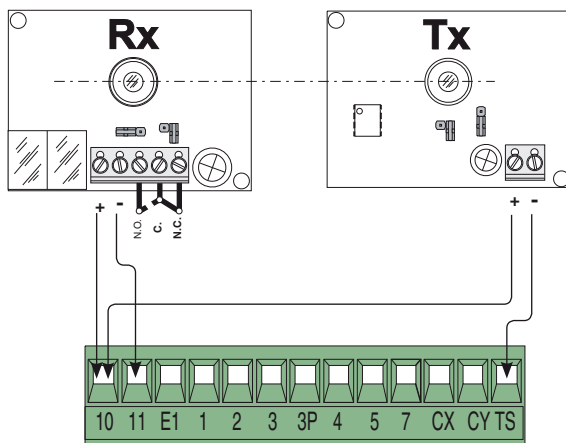

(DIR)

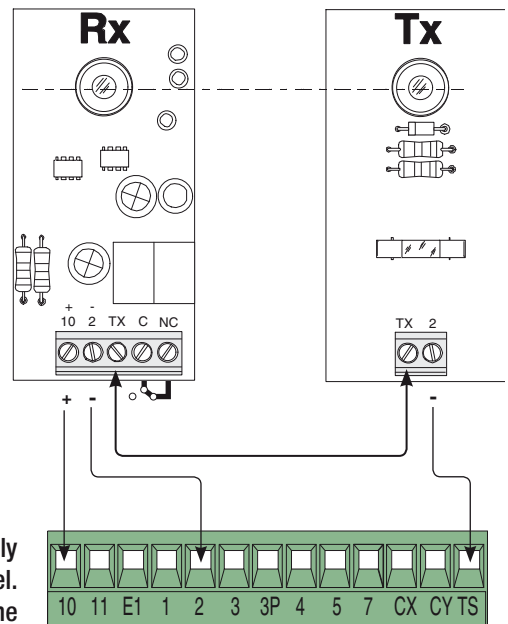

At each opening and closing command, the control board assesses the efficiency status of the control devices (photocells). Any anomaly found is signalled with the flashing of the (PROG) LED on the control panel. Consequently it cancels any commands coming from the remote control or the button.

Electrical connection to enable the photocell safety test:

- the transmitter and the receiver, must be connected as per the diagram;
- set DIP switch 8 to ON to activate test operation.

IMPORTANT:

when running the safety test function, the N.C. contacts, if unused, should be excluded on the relative DIP switches (see chapter 7 "selecting functions").

7 Selecting functions

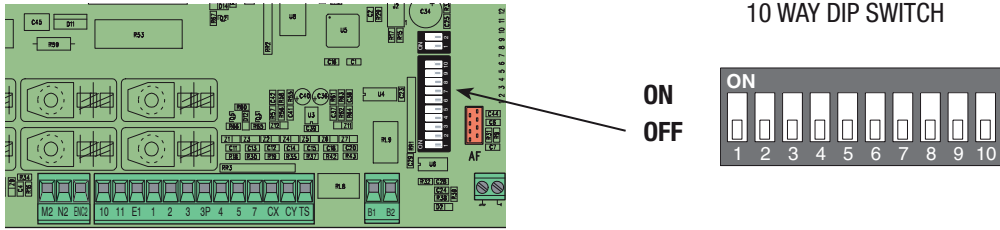

- 1 ON - **Automatic closing** - the automatic closing timer is activated when on opening the gate leaf has reached the full open stroke. The time is preset and adjustable, and is subject to the action of any safety devices. It does not activate after a total safety “stop” or during a power outage;
- 2 ON - **“Open-stop-close-stop”** function with button [2-7] and remote control (with built-in radiofrequency card);
- 2 OFF - **“Open-close-inversion”** function with button [2-7] and remote control (with built-in radiofrequency card);
- 3 ON - **“Open only”** function with remote control (featuring built-in radiofrequency card);
- 4 ON - **Pre-Flashing during opening and closing** - Following an opening or closing command, the flasher connected to [10-E], flashes for 5 seconds before initiating the operation;
- 5 ON - **Obstacle detection** - When motor is idle (gate closed, open or after a total stop command), it prevents any motion if the safety devices (e.g. photocells) detect any obstacle;
- 6 ON - **Maintained action** - the gate works by keeping the button pressed (one button [2-3] for opening, and one button [2-4] for closing);
- 7 ON - Enables to the **command of A1824 operators**;
- 7 OFF - Enables to the **command of FROG J operators**;
- 8 ON - **Operation of the photocells safety test** - this allows the card to assess the efficiency of the safety devices (photocells) after each opening and closing command;
- 9 OFF - **Total stop** - this function halts the gate, consequently excluding any closing cycle; press buttons or remote control to set back in motion. Insert safety devices on 1-2]; if not used, set DIP switch to ON;
- 10 OFF - **Reopening during closing** - if the photocells detect an obstacle during gate closing, the gate motion is inverted until total opening is reached; connect the safety device to terminals [2-CX];

NB -Dip switches 3 and 6 are used, independently, also to activate the electrolock and ram blow (page 7).

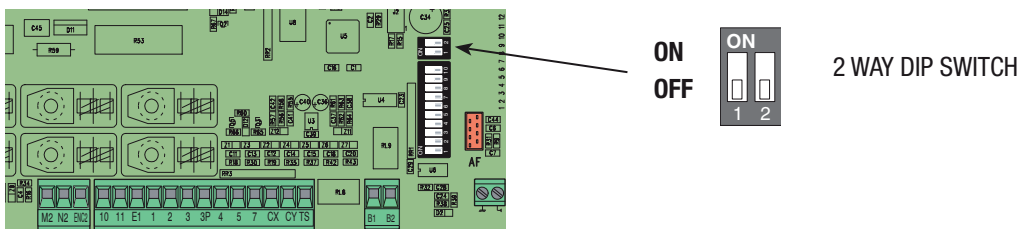

- 1 OFF Enables the obstacle stand-by or partial stop function; connect the safety device to terminals [2-CY]. If device is unused, set the DIP switch to ON;
- 1 OFF - 2 ON **Obstacle stand-by** – stops the gate when there is an obstacle is detected by the safety device; once the obstacle has been cleared, the gate is automatically set back in motion to finish initial run. Connect the safety devices to terminal [2-CY];
- 1 OFF - 2 OFF **Partial stop** – stops gate when an obstacle is detected by the safety devices; once the obstacle is cleared, the gate remains still or closes if the automatic closing function is enabled. Connect the safety devices to terminal [2-CY];

8 Adjustments

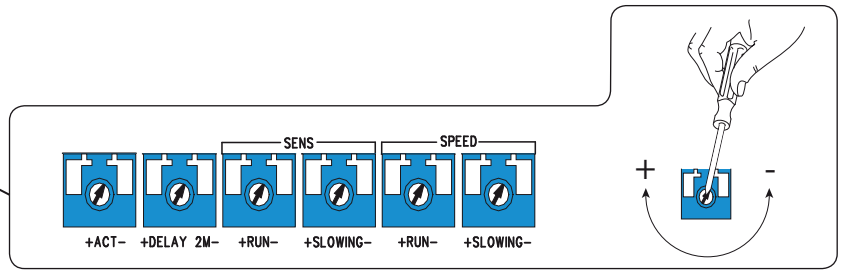
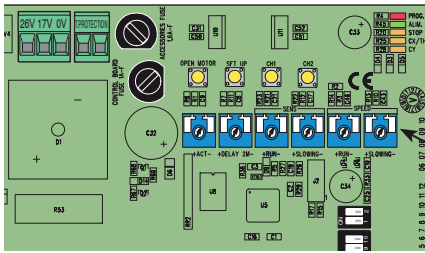

Trimmer ACT	Adjusts the waiting time when gate is open. Once this time has elapsed, the gate closes automatically. The waiting time can be adjusted anywhere between 1 and 150 seconds.
Trimmer DELAY 2M	Adjusts the waiting time of the second motor during each closing run. The waiting time can be adjusted anywhere between 1 and 16 seconds.
Trimmer -- SENS -- RUN	Adjusts the amperometric sensitivity which controls the power developed by the motor during motion; if the power exceeds the adjusted level, the system sets in motion to invert the direction of motion.
Trimmer -- SENS -- SLOWING	Adjusts the amperometric sensitivity which controls the power developed by the motor during slowing down; if the power exceeds the adjusted level, the system sets in motion to invert the direction of motion.
Trimmer -- SPEED -- RUN	Adjusts the gate-leaf running speed when opening or closing.
Trimmer -- SPEED -- SLOWING	Adjusts the gate leaf's slowing speed at the end of the stroke when opening and closing.

9 Signal LED

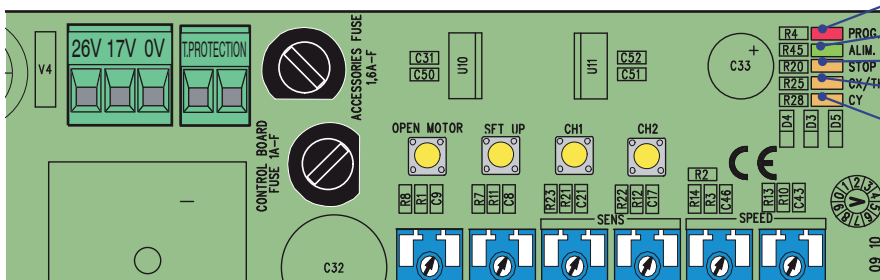

- Led PROG
- Led ALIM.
- Led STOP
- Led CX/TH.
- Led CY

LIST OF CONTROL LED SIGNALS OF THE COMMAND AND SAFETY DEVICES:

- «**PROG**» Red coloured LED. Usually off.
It turns on or flashes when the transmitter is activating or when the system is memorising automatic adjustment.
- «**ALIM**» Green coloured LED. Usually on.
It signals proper power supply to the card.
- «**STOP**» Yellow coloured LED. Usually off.
Signals that the TOTAL STOP button is engaged.
- «**CX/TH**» Yellow coloured LED. Usually off.
Warns of objects present between the photocells (that are set to the REOPEN DURING CLOSING function).
- «**CY**» Yellow coloured LED. Usually off.
Warns of objects present between the photocells (that are set to the PARTIAL STOP or OBSTACLE STAND-BY function).

10 Automatic calibration of the gate run

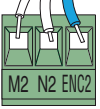

Warning! With single-leaf gates, connect the gearmotor to terminals M2-N2-ENC2. The calibration procedures are the same as those described below

ENGLISH

10.1 - PRELIMINARY ASSESSMENT OF THE DIRECTION OF MOVEMENT DURING OPENING

- Release both gearmotors (see paragraph on “manual release” in the installation manual), position the gate leaves to be half-way open, block the gearmotors again.

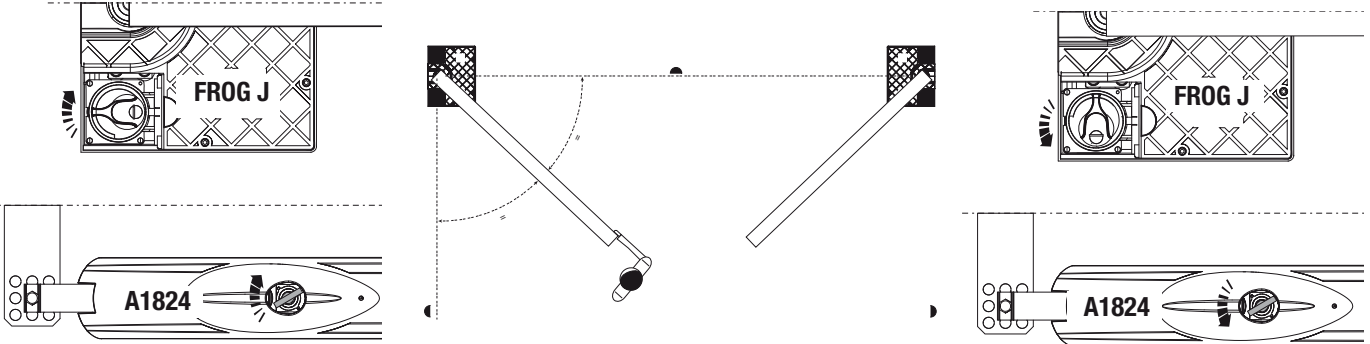

Warning! For Frog J, set Dip switch n. 7 to OFF.
For A1824, set DIP switch n. 7 to ON.
Briefly press the “OPEN MOTOR” button. Check that both gate leaves perform the opening movement.

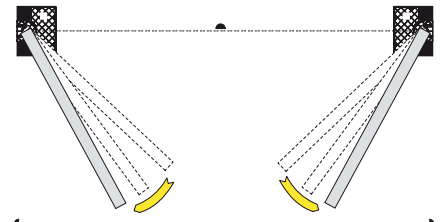
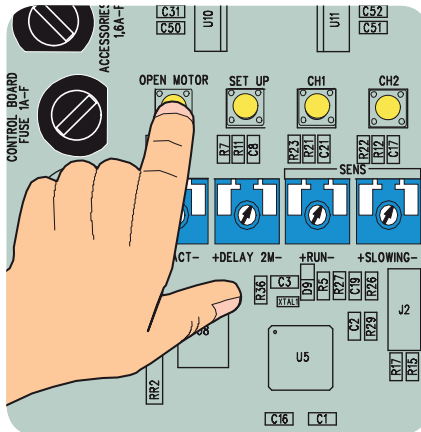
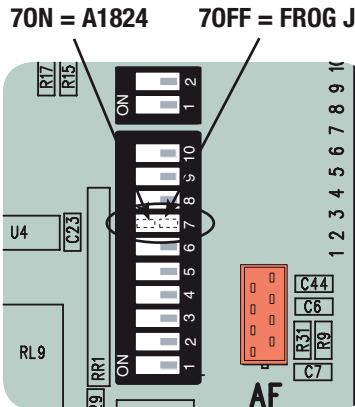

Otherwise:

- 1) if the gate leaves close, invert the M-N phases on either of the gearmotors;
- 2) if the gate leaf of the first gearmotor closes, invert the M1-N1 phase.
- 3) if the gate leaf of the second gearmotor closes, invert the M2-N2 phase

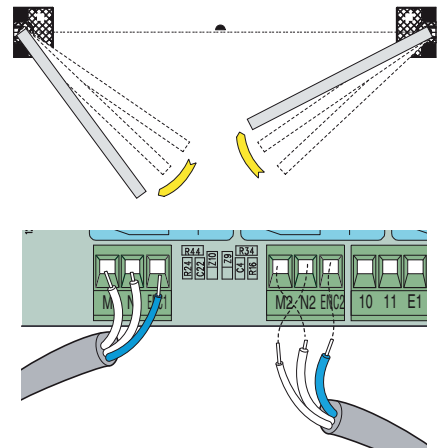
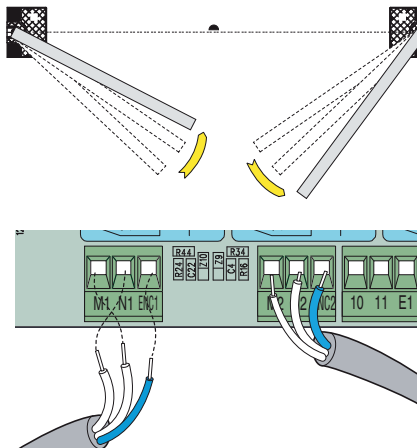
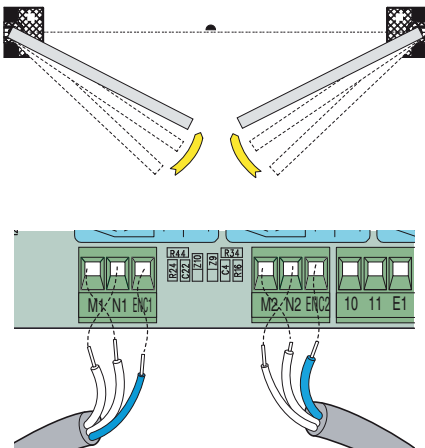

10.2 - PROCESS FOR AUTOMATIC CALIBRATION OF THE GEARMOTORS

- Position the gate leaves so that they are half-way open by pressing on the "OPEN MOTOR" button.

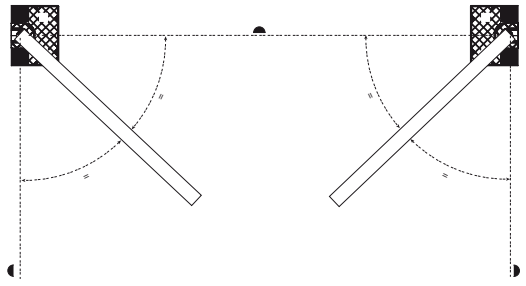
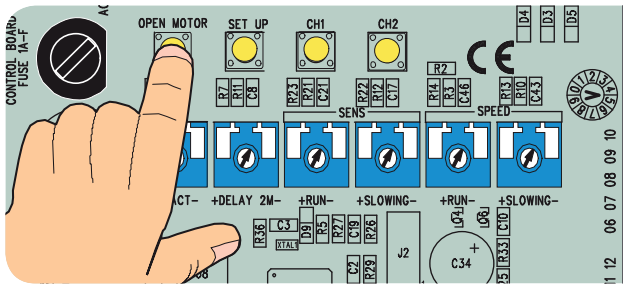

- Press the "SET UP" button for about 3 seconds.

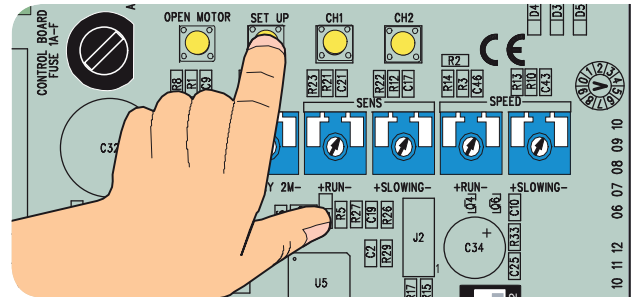

- The gate leaf of the second gearmotor perform a closing run and an opening run, ...

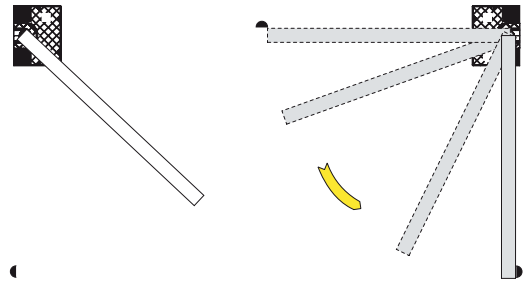
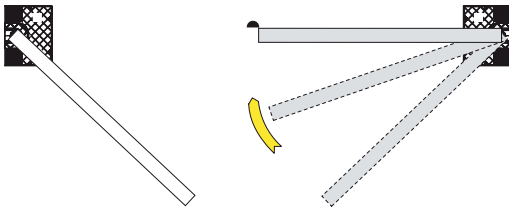

- ...Then, the gate leaf of the first gearmotor performs the same runs.

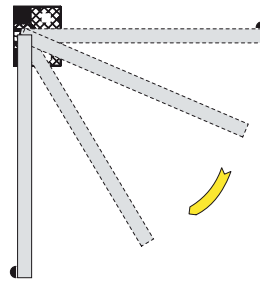
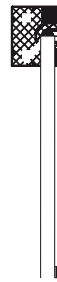
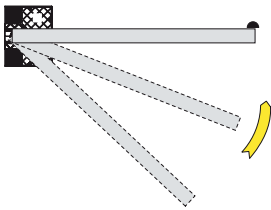

- With gate leaves fully open, the PROG LED stays on for some seconds to show the proper automatic calibration. If the LED flashes check the connections and repeat the calibration procedure.

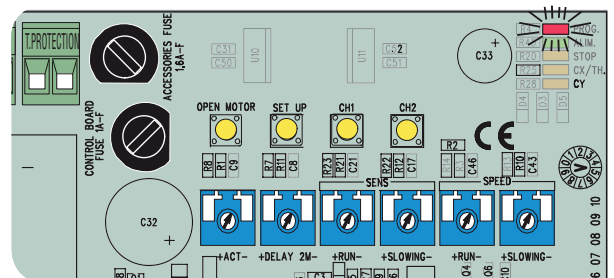

11 Activating the remote control

11.1 - ANTENNA

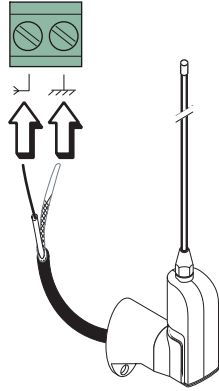

Connect the antenna's RG58 cable to the opposite terminals.



Possible output of the radio receiver's second channel (N.O. socket).
Socket rating: 5A-24V (d.c.).

11.2 - RADIOFREQUENCY CARD

Lock the radiofrequency card into the electronic card AFTER CUTTING OFF THE POWER SUPPLY (or after disconnecting the batteries).

N.B.: the electronic card only recognises the radiofrequency card when the power is on.

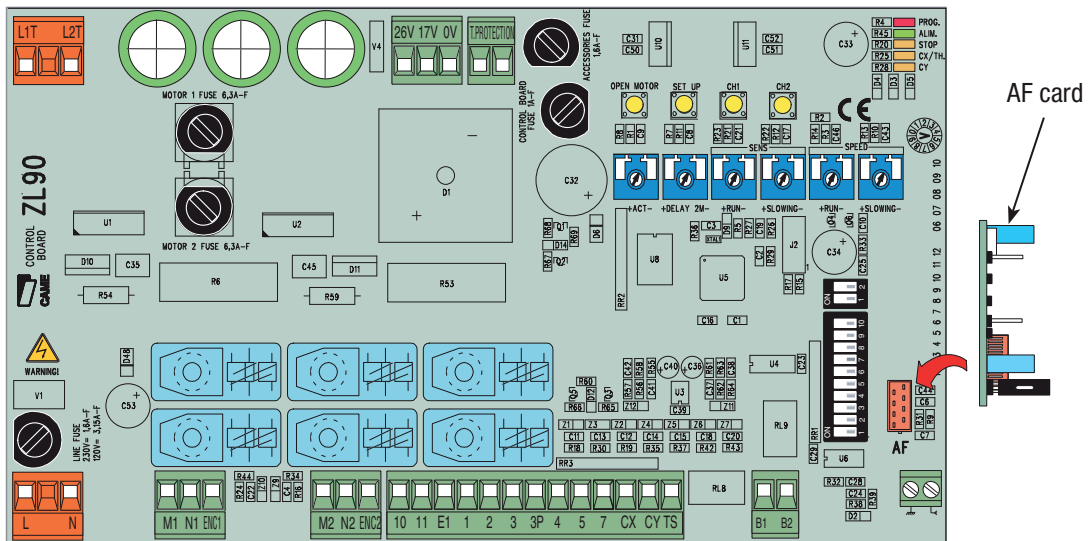

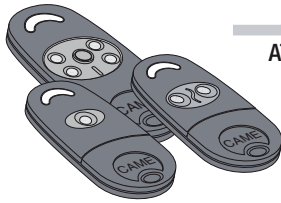

ATOMO
AT01 • AT02
AT04

See instructions attached to AF43SR radiofrequency card

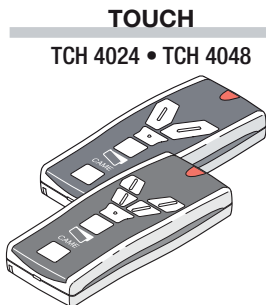

TOUCH
TCH 4024 • TCH 4048

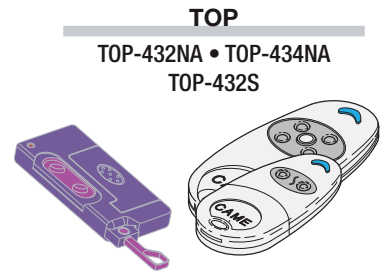

TOP
TOP-432NA • TOP-434NA
TOP-432S

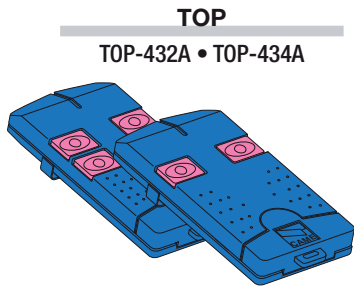

TOP
TOP-432A • TOP-434A

See attached instructions

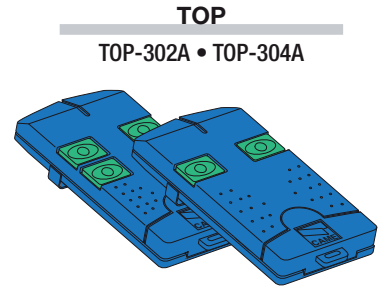

TOP
TOP-302A • TOP-304A

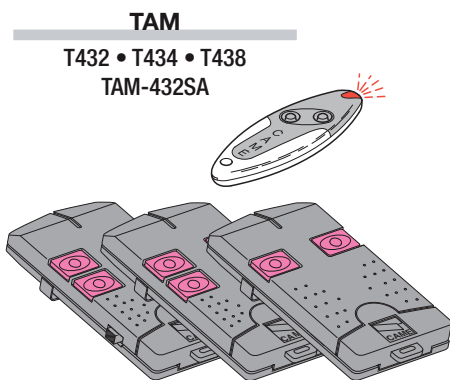

TAM
T432 • T434 • T438
TAM-432SA

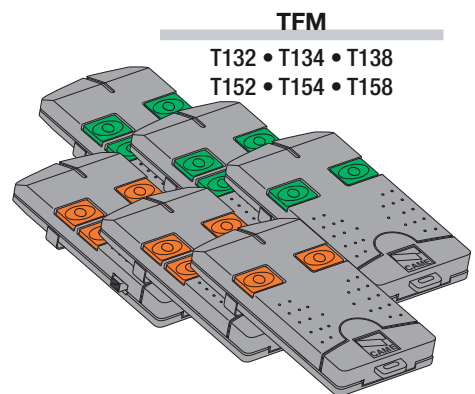

TFM
T132 • T134 • T138
T152 • T154 • T158

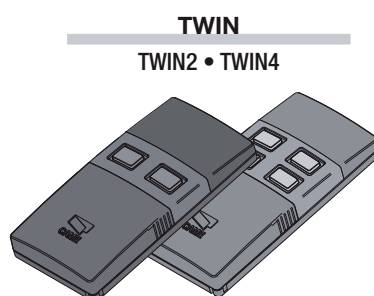

TWIN
TWIN2 • TWIN4

CH1 = Channel for direct command to a function of the the gearmotor’s card, (“open only / “open-close-invert” or “open-stop-close-stop” command, depending on the choice made on DIP switches 2 and 3).

CH2 = Channel for direct command an accessory device connected to B1-B2.

1) Keep the CH1 button on the electronic card pressed. The LED flashes.

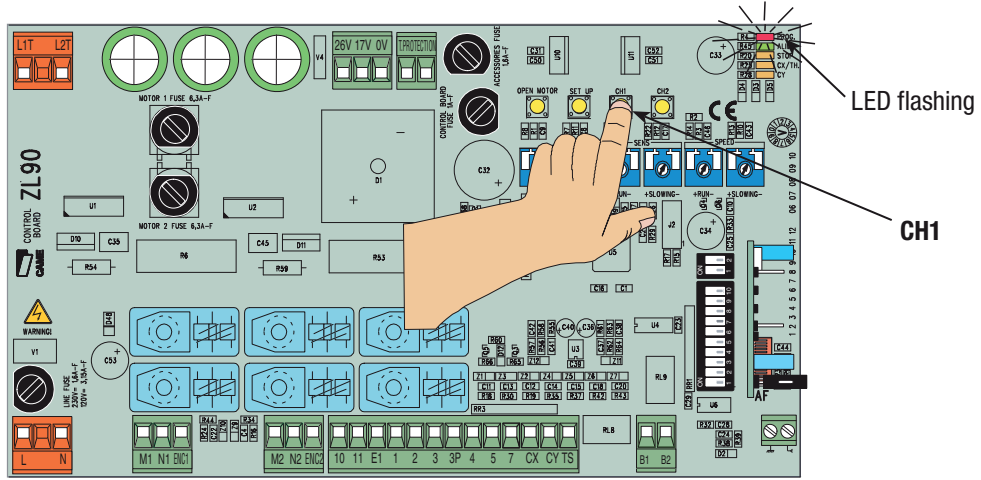

2) Press the transmitter button you wish to memorise. The LED will stay on to show memorisation has been successful.

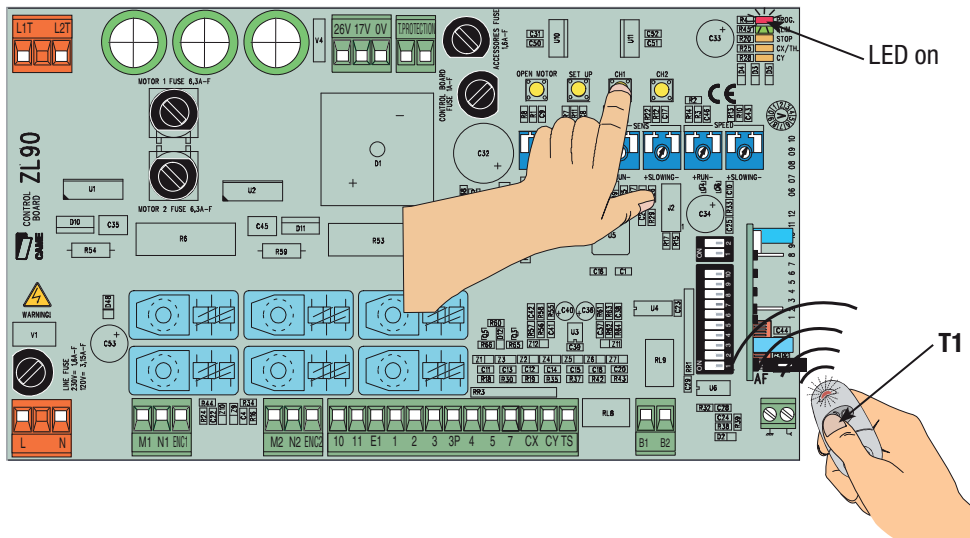

3) Repeat the points 1 and 2 procedures for the “CH2” button associating this to another button on the transmitter.

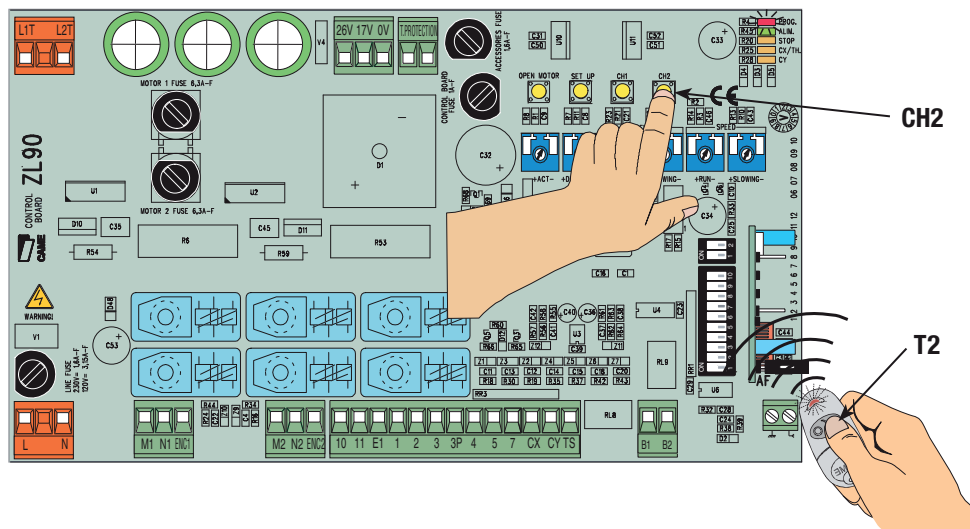

N.B.: to change code, repeat the described procedure.

12 Phasing out and disposal



Our products are made with different types of materials. The majority of these (aluminium, plastic, iron and electrical cables) are part of the solid urban waste category. They can be recycled through licensed waste disposal plants.



Other components (electronic cards, remote control batteries, etc.) constitute hazardous waste. Thus, they are to be removed and delivered to licensed firms that specialise in their proper disposal.

13 Conformity declaration



MANUFACTURER'S DECLARATION OF CONFORMITY

Pursuant to annex II A of the Directive 2006/95/CE



CAME Cancelli Automatici S.p.A.
via Martiri della Libertà, 15
31030 Dosson di Casier - Treviso - ITALY
tel (+39) 0422 4940 - fax (+39) 0422 4941
internet: www.came.it - e-mail: info@came.it

--- STANDARDS ---

EN 60335-1 EN 61000-6-2
EN 60335-2-103 EN 61000-6-3
EN 13241-1

Declares under its own responsibility that the equipments for automatic garage doors and gates listed below:

ZL90

... comply with the National Law related to the following European Directives and to the applicable parts of the following Standards.

--- DIRECTIVES ---

2006/95/CE Low Voltage Directive
2004/108/CE Electromagnetic Compatibility Directive

MANAGING DIRECTOR
Mr. Gianni Michielan

Reference code to request a true copy of the original: **DDC L EN Z002**



English - Manual code: 319U16 ver. 1.0 11/2011 © CAME cancelli automatici s.p.a.
The data and information reported in this installation manual are susceptible to change at any time and without obligation on CAME cancelli automatici s.p.a. to notify users.

<p>CAME France S.a. 7, Rue Des Haras Z.I. Des Hautes Patures 92737 Nanterre Cedex ☎ (+33) 0 825 825 874 ☎ (+33) 1 46 13 05 00</p>	FRANCE	GERMANY	<p>CAME Gmbh Seefeld Akazienstrasse, 9 16356 Seefeld Bei Berlin ☎ (+49) 33 3988390 ☎ (+49) 33 39883985</p>
<p>CAME Automatismes S.a. 3, Rue Odette Jasse 13015 Marseille ☎ (+33) 0 825 825 874 ☎ (+33) 4 91 60 69 05</p>	FRANCE	U.A.E.	<p>CAME Gulf Fze Office No: S10122a2o210 P.O. Box 262853 Jebel Ali Free Zone - Dubai ☎ (+971) 4 8860046 ☎ (+971) 4 8860048</p>
<p>CAME Automatismos S.a. C/Juan De Mariana, N. 17-local 28045 Madrid ☎ (+34) 91 52 85 009 ☎ (+34) 91 46 85 442</p>	SPAIN	RUSSIA	<p>CAME Rus Umc Rus Lic Ul. Otradnaya D. 2b, Str. 2, office 219 127273, Moscow ☎ (+7) 495 739 00 69 ☎ (+7) 495 739 00 69 (ext. 226)</p>
<p>CAME United Kingdom Ltd. Unit 3 Orchard Business Park Town Street, Sandiacre Nottingham - Ng10 5bp ☎ (+44) 115 9210430 ☎ (+44) 115 9210431</p>	GREAT BRITAIN	PORTUGAL	<p>CAME Portugal Ucj Portugal Unipessoal Lda Rua Liebig, nº 23 2830-141 Barreiro ☎ (+351) 21 207 39 67 ☎ (+351) 21 207 39 65</p>
<p>CAME Group Benelux S.a. Zoning Ouest 7 7860 Lessines ☎ (+32) 68 333014 ☎ (+32) 68 338019</p>	BELGIUM	INDIA	<p>CAME India Automation Solutions Pvt. Ltd A - 10, Green Park 110016 - New Delhi ☎ (+91) 11 64640255/256 ☎ (+91) 2678 3510</p>
<p>CAME Americas Automation Lic 11345 NW 122nd St. Medley, FL 33178 ☎ (+1) 305 433 3307 ☎ (+1) 305 396 3331</p>	U.S.A	ASIA	<p>CAME Asia Pacific 60 Alexandra Terrace #09-09 Block C, The ComTech 118 502 Singapore ☎ (+65) 6275 0249 ☎ (+65) 6274 8426</p>
<p>CAME Gmbh Kornwestheimer Str. 37 70825 Korntal Munchingen Bei Stuttgart ☎ (+49) 71 5037830 ☎ (+49) 71 50378383</p>	GERMANY		

<p>CAME Cancelli Automatici S.p.a. Via Martiri Della Libertà, 15 31030 Dosson Di Casler (Tv) ☎ (+39) 0422 4940 ☎ (+39) 0422 4941 Informazioni Commerciali 800 848095</p>	ITALY	ITALY	<p>CAME Sud s.r.l. Via F. Imparato, 198 Centro Mercato 2, Lotto A/7 80146 Napoli ☎ (+39) 081 7524455 ☎ (+39) 081 7529190</p>
<p>CAME Service Italia S.r.l. Via Della Pace, 28 31030 Dosson Di Casler (Tv) ☎ (+39) 0422 383532 ☎ (+39) 0422 490044 Assistenza Tecnica 800 295830</p>	ITALY	ITALY	<p>CAME Global Utilities s.r.l. Via E. Fermi, 31 20060 Gessate (Mi) ☎ (+39) 02 95380366 ☎ (+39) 02 95380224</p>

